

Art 3202

Visual Communications 1

Winter Quarter 2011
M/W 1:00 pm – 4:20 pm

Instructor: Karen Gutowsky
Email: kgz@spu.edu
Office Hours: M-W 1:20-2:00 or by appointment
Course Website: myhome.spu.edu/kgz/3202

Exercise One Mounting Instructions

Board 1—First round of sketches (photocopy and position in frames-9 sketches)

15" x 20" Double Sided Black Matt Board

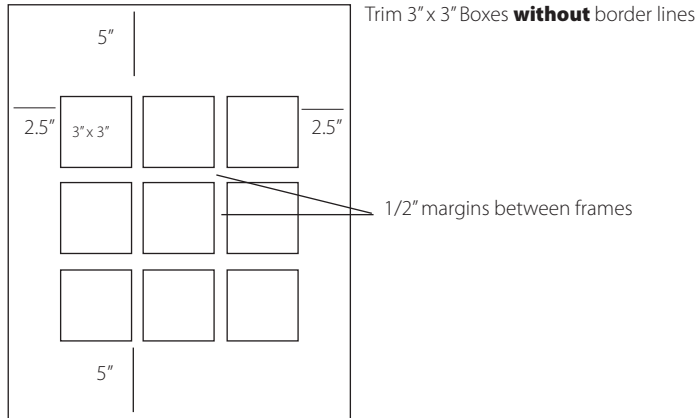

Board 2— More developed sketches (photocopy and position in frames-4 sketches)

15" x 20" Double Sided Black Matt Board

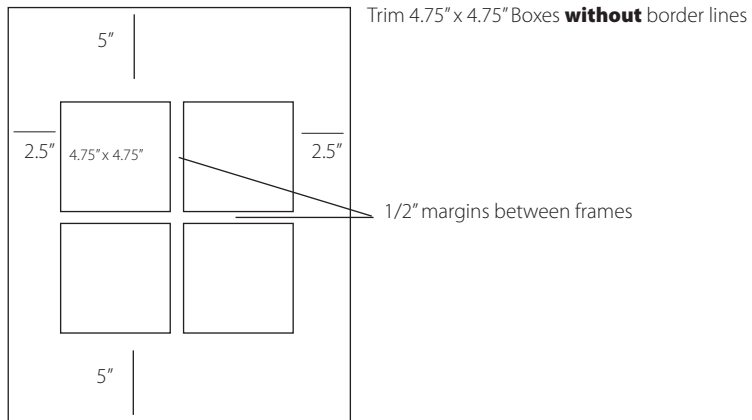

Board 3 & 4—Clean print out of computer rendition of mark and type (one large and one small) and Identity

15" x 20" Double Sided Black Matt Board

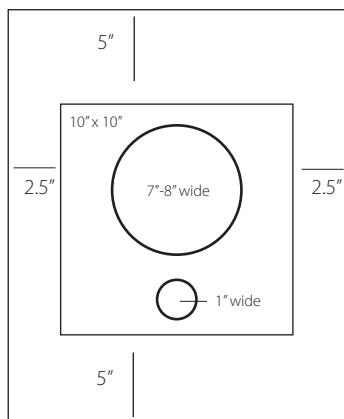

Trim 10" x 10" Box **without** border lines

15" x 20" Double Sided Black Matt Board

